

saip.it



# SI Type KI

Bladder  
accumulators  
in carbon steel  
For pressures  
up to 360 bar

  
**S.AIP**  
energy flow

# Bladder accumulators in carbon steel For pressures up to 360 bar Type SI

## Principle Of Operation

One of the main tasks of accumulators is to take a certain amount of pressurised fluid from a hydraulic system, and then return it, in whole or in part, to the system when required. Bladder accumulators work like a hydraulic spring: the gas (nitrogen), contained in the rubber bladder, is separated from the fluid in the system. When the hydraulic system pressure becomes greater than the pre-charge pressure of the nitrogen, the fluid enters the accumulator and is stored as potential energy inside, due to the compressibility of the gas. When the system fluid pressure decreases, the nitrogen pressure expands and returns the stored fluid to the system.

Operating pressures adapted to the maximum allowable pressure allow a pressurised fluid to be accumulated, stored and recovered at any time.

As pressure vessels, they must be sized for the maximum operating (over) pressure, taking into account the acceptance standards valid in the country of installation.

Bladder-type SI accumulators consist of a seamless cylindrical body made of high-strength steel.

The rubber bladder is mounted inside the body. Through the gas valve, the bladder is filled with nitrogen up to the expected precharge pressure  $P_0$  (special equipment must be used for precharge).

The 'mushroom' valve, located at the bottom on the fluid side, closes if the gas pressure is higher than the fluid pressure. This prevents the bladder from entering the fluid line and being destroyed. When the minimum working pressure is reached, it is necessary that a small volume of fluid (approx. 10% of the nominal volume of the accumulator) remains between the bladder and the mushroom valve, to prevent the bladder from hitting the valve during each expansion process.

The standard poppet valve is available in the threaded (or SAE shank) connections shown in the table.

The top plate contains the technical data and characteristics of the hydraulic accumulator.

Bladder accumulators can be installed vertically, in a tilted position (with the oil valve at the bottom), or horizontally. If the installation position is horizontal or inclined, the effective fluid volume and the maximum permissible flow rate of the operating fluid are reduced.



## Product Description

Repairable bladder accumulator with seamless, painted carbon steel body for use in mobile machines and stationary systems.

## Applications

- Energy reserve in systems with intermittent operation due to reduced pump power.
- Energy reserve for emergency cases, such as in the event of pump-motor unit failure or power failure.
- Compensation of losses due to leakage.
- Pressure compensator (balancing).
- Vibration dampening in the event of periodic oscillations.
- Volume compensation in the event of pressure and temperature variations.
- Hydraulic suspension spring on vehicles.
- Shock absorption in the event of mechanical impact.
- Pulsation damping

## Suggested positions for certain applications

**Energy storage:** vertical

**Pulsation damping:** any position

**Constant pressure maintenance:** any position

**Volume compensation:** vertical

## Features

- A** Seamless body
- B** Bag
- C** Bag valve 7/8" UNF
- D** Gas valve 5/8" UNF
- E** Mushroom valve
- F** Nameplate

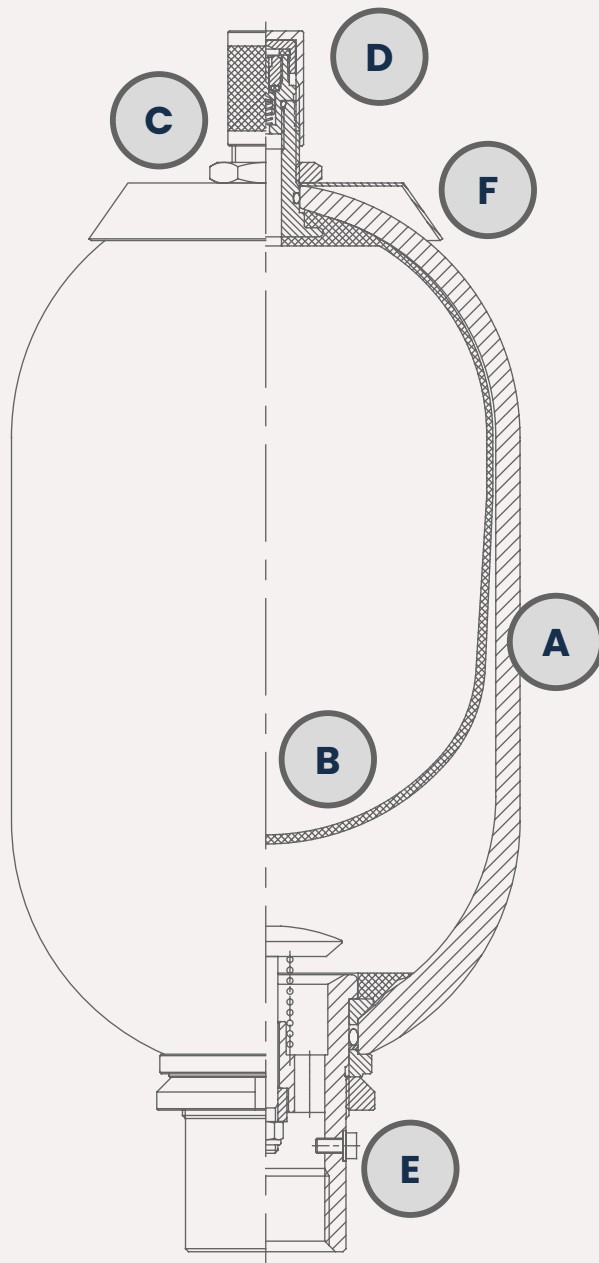

## General characteristics

Nominal volume  
from 4 to 50 litres

Up to  
MAX pressure 360 barg

In accordance with:  
PED 2014/68/EU  
EN 14359  
EN13445-3  
ASME VIII Div. 1

## Technical features

Repairable construction

Seamless high-strength  
steel body

painted

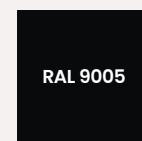

Gas side connection 5/8" UNF.

Fluid-side connection  
(see table)

Separator element material  
(see table)

# Type SI

 bladder accumulators in carbon steel for pressures up to 360 bar

## Description

Accumulator /Pulsation damper type SI - Valv. 5/8" UNF - Stem 7/8" UNF - Vol. 35 L - NBR - CARB. STEEL - F. 2" GAS Sv.

CODE EXAMPLE *														
SI	.	IU	.	35	.	1	.	O	.	C9	.	A	.	
1		2		3		4		5		6		7		8

## Description

Accumulator /Pulsation damper type SI - Valv. 5/8" UNF - Stem 7/8" UNF - Vol. 10 L - FKM - CARB. STEEL - 2" SAE 3000 Flange Shank

CODE EXAMPLE *														
SI	.	IU	.	10	.	10	.	O	.	F	.	B	.	CSO3G
1		2		3		4		5		6		7		8

1. ACCUMULATOR TYPE		3. NOMINAL VOLUME		6. FLUID CONNECTION		FLANGE SHANK	
<b>SI</b>		<b>4</b>	L	<b>C7</b>	F. 1 1/4" BSP-P	<b>CSO3E</b>	1 1/4" SAE 3000
		<b>6</b>	L	<b>F</b>	SAE Flange shank	<b>CSO6E</b>	1 1/4" SAE 6000
<b>2. GAS CONNECTON (NITROGEN)</b>		<b>10L</b>	L	<b>C7</b>	F. 1 1/4" BSP-P	<b>CSO3E</b>	1 1/4" SAE 3000
<b>IU</b>	Stem 7/8" UNF gas valve 5/8" UNFF	<b>10</b>	L	<b>F</b>	SAE Flange shank	<b>CSO6E</b>	1 1/4" SAE 6000
<b>4. SEPARATOR ELEMENT MATERIAL</b>		<b>10</b>	L	<b>C7</b>	F. 1 1/4" BSP-P	<b>CSO3E</b>	1 1/4" SAE 3000
<b>1</b>	Nitrile (NBR)	<b>20</b>	L	<b>F</b>	SAE Flange shank	<b>CSO6E</b>	1 1/4" SAE 6000
<b>1C</b>	Low temp. Nitrile. (NBR -40°C)	<b>25</b>	L	<b>C9</b>	F. 2" BSP-P	<b>CSO3F</b>	1 1/2" SAE 3000
<b>1F</b>	Nitrile for hydrocarbons (NBR)	<b>35</b>	L	<b>F</b>	SAE Flange shank	<b>CSO6F</b>	1 1/2" SAE 6000
<b>6</b>	Hydrogenated Nitrile (H-NBR)	<b>42</b>	L	<b>C9</b>	F. 2" BSP-P	<b>CSO3G</b>	2" SAE 3000
<b>8</b>	Epichlorohydrin (ECO)	<b>55</b>	L	<b>F</b>	SAE Flange shank	<b>CSO6G</b>	2" SAE 6000
<b>2</b>	Butyl			<b>C9</b>	F. 2" BSP-P	<b>CSO3F</b>	1 1/2" SAE 3000
<b>4</b>	Ethylene/propylene (EPDM)			<b>F</b>	SAE Flange shank	<b>CSO6F</b>	1 1/2" SAE 6000
<b>5</b>	Chloroprene (Neoprene)			<b>C9</b>	F. 2" BSP-P	<b>CSO3G</b>	2" SAE 3000
<b>10</b>	Fluororated Rubber (FKM)			<b>F</b>	SAE Flange shank	<b>CSO6G</b>	2" SAE 6000
<b>5. BODY MATERIAL</b>				<b>C9</b>	F. 2" BSP-P	<b>CSO3F</b>	1 1/2" SAE 3000
<b>O</b>	Carbon steel			<b>F</b>	SAE Flange shank	<b>CSO6F</b>	1 1/2" SAE 6000
<b>7. CERTIFICATION</b>				<b>C9</b>	F. 2" BSP-P	<b>CSO3G</b>	2" SAE 3000
<b>A</b>	PED 2014/68/EU EN 14359:2017 EN13445-3:2021			<b>F</b>	SAE Flange shank	<b>CSO6G</b>	2" SAE 6000
<b>E</b>	PED 2014/68/EU ASME VIII Div.1			<b>C9</b>	F. 2" BSP-P	<b>CSO3F</b>	1 1/2" SAE 3000
<b>B</b>	ASME VIII Div.1 U-STAMP			<b>F</b>	SAE Flange shank	<b>CSO6F</b>	1 1/2" SAE 6000
						<b>CSO3G</b>	2" SAE 3000
						<b>CSO6G</b>	2" SAE 6000

\* For different codes or features please contact SAIP

BLADDER COMPATIBILITY / TEMPERATURE / FLUID *			
<b>1</b>	Rubber Perbunan (NBR)	-15 / +80°C	<b>Suitable for:</b> <ul style="list-style-type: none"> <li>- Mineral fats and oils</li> <li>- Aliphatic hydrocarbons (propane, butane, petrol, oils, mineral fats, diesel fuel, fuel oil, kerosene)</li> <li>- HFA - HFB - HFC fluids</li> <li>- Many dilute acids</li> <li>- Saline solutions</li> <li>- Water</li> <li>- Glycol water</li> </ul>
<b>1C</b>	Low temp. Nitrile (NBR -40°C)	-40 / +70°C	<b>Suitable for:</b> <ul style="list-style-type: none"> <li>- Fluids such as for standard NBR (see above)</li> <li>- Various types of freon</li> </ul>
<b>1F</b>	Nitrile for Hydrocarbons (NBR)	-10 / +90°C	<b>Suitable for:</b> <ul style="list-style-type: none"> <li>- Fluids such as for standard NBR (see above)</li> <li>- Heavy fuel oil</li> <li>- Normal and super (low aromatic) petrol</li> </ul>
<b>6</b>	Hydrogenated Nitrile (H-NBR)	-30 / +130°C	<b>Suitable for:</b> <p>Fluids such as for standard NBR (see above) with excellent low and high temperature performance; higher chemical resistance</p>
<b>8</b>	Rubber in Epichlorohydrin (ECO)	-30 / +120°C	<p>Low gas permeability, good resistance to ozone, ageing and weathering.</p> <b>Suitable for:</b> <ul style="list-style-type: none"> <li>- Mineral fats and oils</li> <li>- Aliphatic hydrocarbons (propane, butane, petrol)</li> <li>- Silicone oils and greases</li> <li>- Water at room temperature</li> </ul>
<b>2</b>	Butyl	-20 / +100°C	<b>Suitable for:</b> <ul style="list-style-type: none"> <li>- Hot water up to 100° C</li> <li>- glycol-based brake fluids</li> <li>- silicone oils and greases</li> <li>- many acids and bases of phosphoric acid esters</li> <li>- salt solutions, polar solvents such as alcohols, ketones and esters</li> <li>- polyglycol-based hydraulic fluids</li> </ul>
<b>4</b>	Ethylene/propylene (EPDM)	-30 / +130°C	<b>Suitable for:</b> <ul style="list-style-type: none"> <li>- Hot water up to 100° C</li> <li>- glycol-based brake fluids</li> <li>- silicone oils and greases</li> <li>- many acids and bases of phosphoric acid esters</li> <li>- many polar solvents such as alcohols, ketones and esters</li> </ul>
<b>5</b>	Chloroprene (Neoprene)	-30 / +100°C	<b>Suitable for:</b> <ul style="list-style-type: none"> <li>- mineral paraffin oils, silicone oils and greases</li> <li>- naphthenic mineral oils, low molecular aliphatic hydrocarbons (propane, butane, petrol)</li> <li>- glycol-based brake fluids</li> <li>- water and aqueous solutions, refrigerants (ammonia, carbon dioxide, Freon) ketones and esters</li> </ul>
<b>10</b>	Fluororated Rubber (FKM)	10 / +150°C	<b>Suitable for:</b> <ul style="list-style-type: none"> <li>- Mineral oils and fats, silicone oils and fats, animal and vegetable oils and fats</li> <li>- aliphatic hydrocarbons (petrol, butane, propane, natural gas), aromatic hydrocarbons (benzole, toluol)</li> <li>- chlorinated hydrocarbons (tetrachloroethylene, carbon tetrachloride)</li> <li>- fuels (normal, super and methanol-containing)</li> <li>- non-flammable fluids of the HFD group</li> </ul>

\* For the use with different fluids and/or temperatures please contact SAIP

# Type SI bladder accumulators in carbon steel for pressures up to 360 bar

## THREADED Fluid Connection

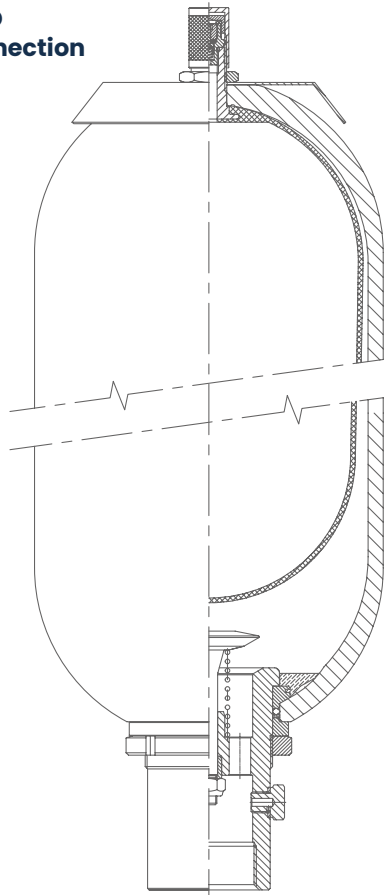

## SAE 3000 and SAE 6000 Fluid Connection

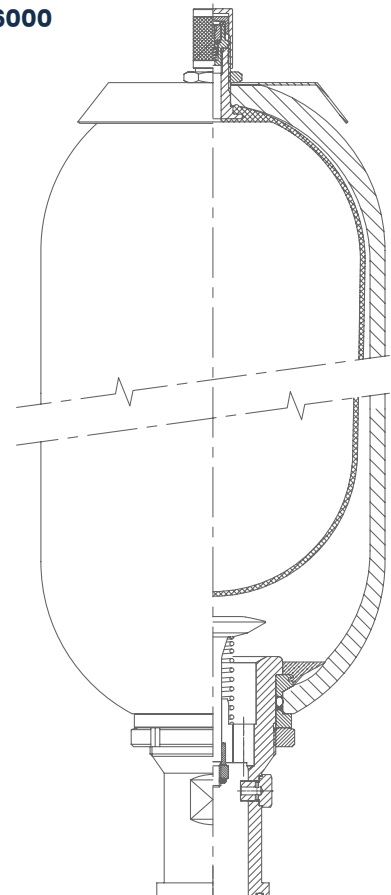

### Technical Data Threaded Fluid Connection

Type	Nominal volume [L]	Effective Volume [L]	Design pressure EN(1) [barg]	Design pressure ASME (2) [barg]	$\Delta P$ MAX <sup>(3)</sup> dynamic P2 - P1 [barg]	MAX compression ratio P0 : p <sub>2</sub>	Flowrate MA <sup>(4)</sup> [L/min]	Precharge MAX <sup>(5)</sup> [barg]	PED Category (for Group 2 fluids)	Weight [kg]
SI 4	3,8	4	360	250	200	4:1	450	250	Cat. III	14
SI 6	5,8	6	360	250	200	4:1	450	250	Cat. III	19
SI 10L	9,3	10	360	250	200	4:1	450	250	Cat. IV	31
SI 10	9,6	10	360	250	100	4:1	900	250	Cat. IV	33
SI 20	18,2	20	360	250	100	4:1	900	250	Cat. IV	48
SI 25	23,5	25	360	250	100	4:1	900	250	Cat. IV	53
SI 35	33,5	35	360	250	100	4:1	900	250	Cat. IV	78
SI 42	40,5	42	360	250	100	4:1	900	250	Cat. IV	90
SI 55	50	55	360	250	100	4:1	900	250	Cat. IV	110

(1) Design pressure calculated according to EN14359:2017 (for pressure values according to other norms please contact SAIP)

(2) Design pressure calculated according to ASME VIII Div.1 – Appendix 22 (for pressure values according to other norms please contact SAIP)

(3) Maximum admissible differential pressure (pressure difference between the maximum operating pressure P2 and the minimum operating pressure P1) to have an infinite life cycle (more than 2.000.000 cycles)

(4) Flowrate measured using mineral oil with viscosity of 36 cSt at 50 °C and  $\Delta P = 5$  bar

(5) For higher values please contact SAIP

### Technical Data SAE 3000 Fluid Connection

Type	Nominal volume	Effective Volume	Design pressure EN(1)	Design pressure ASME (2)	$\Delta P$ MAX <sup>(3)</sup> dynamic P2 - P1	MAX compression ratio P0: p <sub>2</sub>	Flowrate MAX <sup>(4)</sup>	Precharge MAX <sup>(5)</sup>	PED Category (for Group 2 fluids)	Weight
	[L]	[L]	[barg]	[barg]	[barg]		[L/min]	[barg]		[kg]
SI 4	3,8	4	207	207	200	4:1	450	140	Cat: II	14
SI 6	5,8	6	207	207	200	4:1	450	140	Cat: III	19
SI 10L	9,3	10	207	207	200	4:1	450	140	Cat: III	31
SI 10	9,6	10	207	207	100	4:1	900	140	Cat: III	33
SI 20	18,2	20	207	207	100	4:1	900	140	Cat: IV	48
SI 25	23,5	25	207	207	100	4:1	900	140	Cat: IV	53
SI 35	33,5	35	207	207	100	4:1	900	140	Cat: IV	78
SI 42	40,5	42	207	207	100	4:1	900	140	Cat: IV	90
SI 55	50	55	207	207	100	4:1	900	140	Cat: IV	110

### Technical Data SAE 6000 Fluid Connection

Type	Nominal volume	Effective Volume	Design pressure EN(1)	Design pressure ASME (2)	$\Delta P$ MAX <sup>(3)</sup> dynamic P2 - P1	MAX compression ratio P0: p <sub>2</sub>	Flowrate MAX <sup>(4)</sup>	Precharge MAX <sup>(5)</sup>	PED Category (for Group 2 fluids)	Weight
	[L]	[L]	[barg]	[barg]	[barg]		[L/min]	[barg]		[kg]
SI 4	3,8	4	360	250	200	4:1	450	250	Cat: III	14
SI 6	5,8	6	360	250	200	4:1	450	250	Cat: III	19
SI 10L	9,3	10	360	250	200	4:1	450	250	Cat: IV	31
SI 10	9,6	10	360	250	100	4:1	900	250	Cat: IV	33
SI 20	18,2	20	360	250	100	4:1	900	250	Cat: IV	48
SI 25	23,5	25	360	250	100	4:1	900	250	Cat: IV	53
SI 35	33,5	35	360	250	100	4:1	900	250	Cat: IV	78
SI 42	40,5	42	360	250	100	4:1	900	250	Cat: IV	90
SI 55	50	55	360	250	100	4:1	900	250	Cat: IV	110

(1) Design pressure calculated according to EN14359:2017 (for pressure values according to other norms please contact SAIP)

(2) Design pressure calculated according to ASME VIII Div.1 – Appendix 22 (for pressure values according to other norms please contact SAIP)

(3) Maximum admissible differential pressure (pressure difference between the maximum operating pressure P2 and the minimum operating pressure P1) to have an infinite life cycle (more than 2.000.000 cycles)

(4) Flowrate measured using mineral oil with viscosity of 36 cSt at 50 °C and  $\Delta P = 5$  bar

(5) For higher values please contact SAIP

# Type SI bladder accumulators in carbon steel for pressures up to 360 bar

## THREADED Fluid Connection

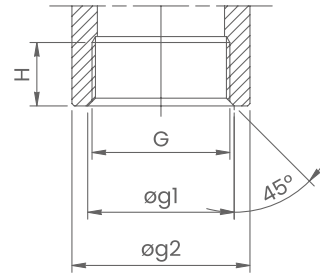
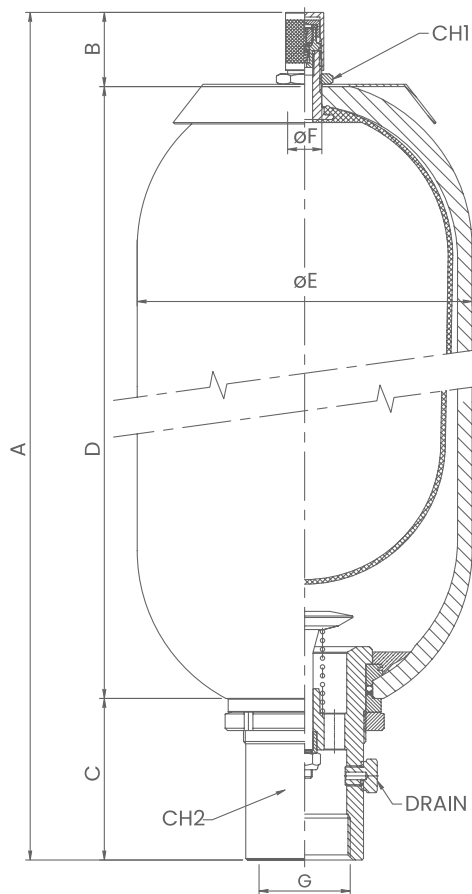

G	$\varnothing g1$	$\varnothing g2$	H
F. 1.1/4" BSP-P	46	53	25
F. 2" BSP-P	63,35	77	28

## Dimensions

Type	Gas connection (nitrogen)	Fluid connection	A	B	C	D	$\varnothing E$	$\varnothing F$	CH1	CH2	DRAIN
			[mm $\pm 10$ ]	[mm $\pm 2$ ]	[mm $\pm 2$ ]	[mm $\pm 10$ ]	[mm $\pm 1$ ]	[mm]	[mm]	[mm]	
SI 4	5/8" UNF Valve	F. 1.1/4" BSP-P	403	51	65	287	168	22,5	32	50	M5
SI 6	5/8" UNF Valve	F. 1.1/4" BSP-P	532	51	65	416	168	22,5	32	50	M5
SI 10L	5/8" UNF Valve	F. 1.1/4" BSP-P	797	51	65	681	168	22,5	32	50	M5
SI 10	5/8" UNF Valve	F. 2" BSP-P	561	50	106	405	219	22,5	32	70	1/4" BSP-P
SI 20	5/8" UNF Valve	F. 2" BSP-P	871	50	106	715	219	22,5	32	70	1/4" BSP-P
SI 25	5/8" UNF Valve	F. 2" BSP-P	1036	50	106	880	219	22,5	32	70	1/4" BSP-P
SI 35	5/8" UNF Valve	F. 2" BSP-P	1386	50	106	1230	219	22,5	32	70	1/4" BSP-P
SI 42	5/8" UNF Valve	F. 2" BSP-P	1526	50	106	1370	219	22,5	32	70	1/4" BSP-P
SI 55	5/8" UNF Valve	F. 2" BSP-P	1896	50	106	1740	219	22,5	32	70	1/4" BSP-P



**SAE 3000 and SAE 6000  
Fluid Connection**

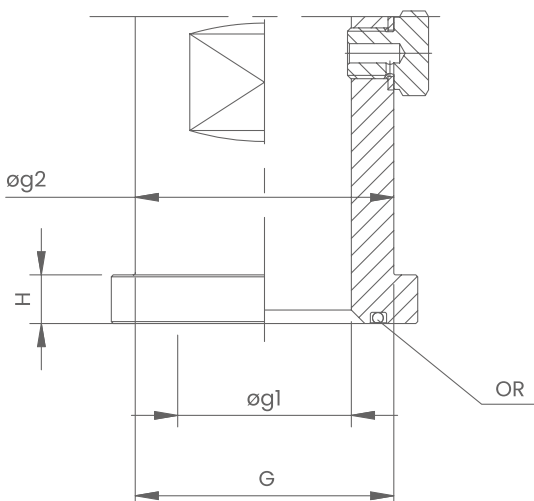
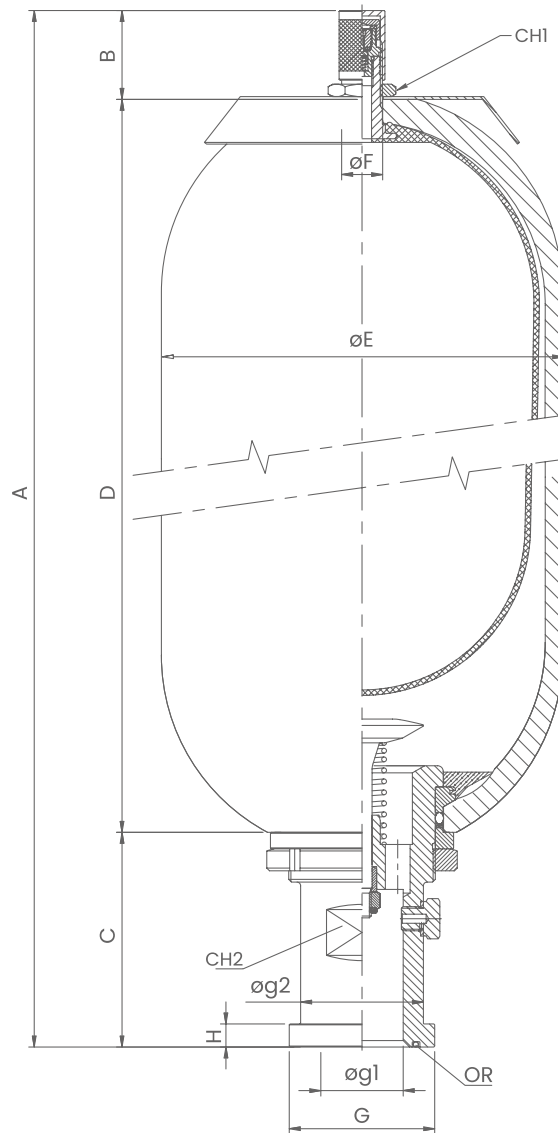

G	Øg1	Øg2	H	OR
<b>1.1/4" SAE 3000 Ø50,8</b>	31	43	8	OR 4150
<b>1.1/4" SAE 6000 Ø53,3</b>	31	44	10,3	OR 4150
<b>1.1/2" SAE 3000 Ø60,3</b>	32	50	8	OR 4187
<b>1.1/2" SAE 6000 Ø63,5</b>	32	51	12,5	OR 4187
<b>2" SAE 3000 Ø71,5</b>	45	62	9,5	OR 4225
<b>2" SAE 6000 Ø77,6</b>	45	67	12,5	OR 4225

# Type SI bladder accumulators in carbon steel for pressures up to 360 bar

## SAE 3000 and SAE 6000 Fluid Connection

Dimensions											
Type	Gas connection (nitrogen)	Fluid connection	A	B	C	D	øE	øF	CH1	CH2	DRAIN
			[mm ±10]	[mm ±2]	[mm ±2]	[mm ±10]	[mm ±1]	[mm]	[mm]	[mm]	
SI 4	5/8" UNF Valve	1.1/4" SAE 3000	403	51	89	287	168	22,5	32	38	M5
		1.1/4" SAE 6000									
SI 6	5/8" UNF Valve	1.1/4" SAE 3000	532	51	89	416	168	22,5	32	38	M5
		1.1/4" SAE 6000									
SI 10L	5/8" UNF Valve	1.1/4" SAE 3000	797	51	89	681	168	22,5	32	38	M5
		1.1/4" SAE 6000									
SI 10	5/8" UNF Valve	1.1/2" SAE 3000	561	50	115	405	219	22,5	32	42	1/4" BSP-P
		1.1/2" SAE 6000								55	
		2" SAE 3000									
		2" SAE 6000									
SI 20	5/8" UNF Valve	1.1/2" SAE 3000	871	50	115	715	219	22,5	32	42	1/4" BSP-P
		1.1/2" SAE 6000								55	
		2" SAE 3000									
		2" SAE 6000									
SI 25	5/8" UNF Valve	1.1/2" SAE 3000	1036	50	115	880	219	22,5	32	42	1/4" BSP-P
		1.1/2" SAE 6000								55	
		2" SAE 3000									
		2" SAE 6000									
SI 35	5/8" UNF Valve	1.1/2" SAE 3000	1386	50	115	1230	219	22,5	32	42	1/4" BSP-P
		1.1/2" SAE 6000								55	
		2" SAE 3000									
		2" SAE 6000									
SI 42	5/8" UNF Valve	1.1/2" SAE 3000	1526	50	115	1370	219	22,5	32	42	1/4" BSP-P
		1.1/2" SAE 6000								55	
		2" SAE 3000									
		2" SAE 6000									
SI 55	5/8" UNF Valve	1.1/2" SAE 3000	1896	50	115	1740	219	22,5	32	42	1/4" BSP-P
		1.1/2" SAE 6000								55	
		2" SAE 3000									
		2" SAE 6000									

## Sizing

For the sizing of an accumulator sizing various factors have to be considered:

- Minimum (P1) and maximum (P2) working pressures
- Minimum (T1) and maximum (T2) working temperatures
- Precharge pressure (P0)
- Required volumes

The formulas for correct dimensioning can be found in the **GENERAL INFORMATION -> SIZING**

## Certifications

All hydraulic accumulators are pressure vessels and are subject to the national regulations and directives in force in the country of installation.

The accumulators type SI are manufactured in accordance with the European Directive PED 2014/68/EU, reference standards EN 14359:2017 and EN13445-3:2021; they are also in accordance with ASME VIII Div. 1 - Appendix 22, with U-STAMP. The Technical Data table shows the category for use with non-hazardous fluids (group 2).

For use with hazardous fluids (group 1), please contact SAIP.

For other countries, applications, regulations, please contact SAIP.

## State conditions

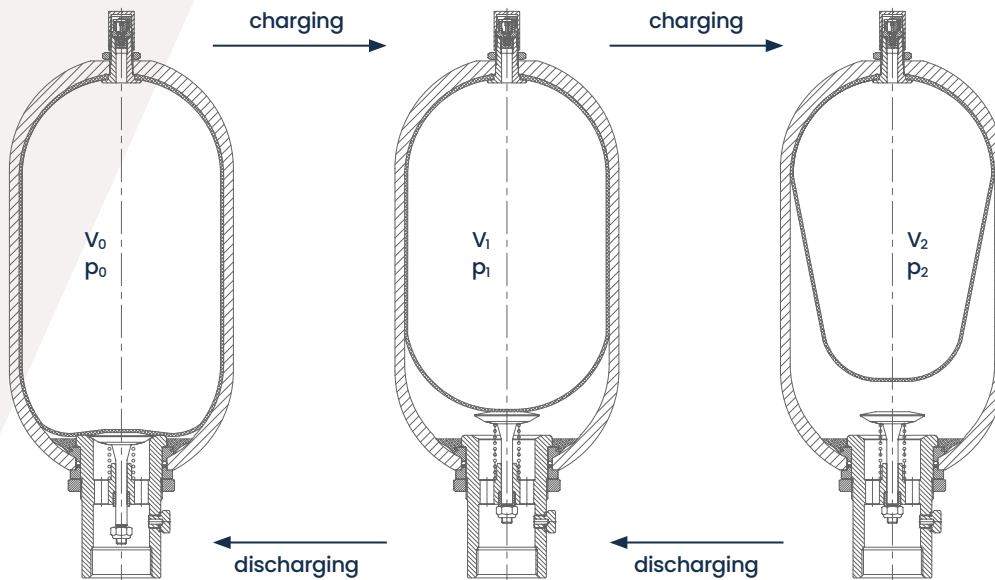

## Information for Use

Refer to SAIP documents:

- MAINTENANCE AND OPERATING MANUAL SI
- MAINTENANCE, OPERATING, STORING AND CONSERVATION MANUAL FOR HYDROPNEUMATIC ACCUMULATORS / PULSATION DAMPERS
- INSTRUCTIONS FOR THE PRE-CHARGE OF THE HYDROPNEUMATIC ACCUMULATORS UP TO 350 bar MAX

## Safety equipment

Notice:

Hydropneumatic accumulators must be protected against operation outside the permissible limits according to the Pressure Equipment Directive 2014/68/EU.

In order not to exceed the maximum operating pressure, SAIP recommends the use of a safety block.

### CAUTION!

**HIGH PRESSURE ACCUMULATOR. NEVER USE OXYGEN OR SHOP AIR.**

1. Do not operate without sufficient dry nitrogen gas precharge.
2. Release all pressure prior to servicing or disassembly.
3. Consult the instruction manual before use.
4. Do not operate beyond stamped maximum working pressure.
5. Do not weld or modify this unit in any way.

# Type SI bladder accumulators in carbon steel for pressures up to 360 bar

## Spare parts

Type	Complete Bladder assembly	Only 5/8" UNF nitrogen valve	Complete poppet valve assembly	Rubber support ring only	O'ring	Parbak
	1	1v	2	2a	2o	2p
SI 4	MEMSI4-xxOZ78V-V2ORGT	VALPRE58OZ-IV2	VALFUN1140-61-xxC7	ANEVAL1140-61-xx	ORI59-xx	PARI59-12-I
SI 6	MEMSI6-xxOZ78V-V2ORGT	VALPRE58OZ-IV2	VALFUN1140-61-xxC7	ANEVAL1140-61-xx	ORI59-xx	PARI59-12-I
SI 10L	MEMSI10L-xxOZ78V-V2ORGT	VALPRE58OZ-IV2	VALFUN1140-61-xxC7	ANEVAL1140-61-xx	ORI59-xx	PARI59-12-I
SI 10	MEMSI10-xxOZ78V-V2ORGT	VALPRE58OZ-IV2	VALFUN20-xxC9	ANEVAL20-89-xx	ORI81-xx	PARI81-12-I
SI 20	MEMSI20-xxOZ78V-V2ORGT	VALPRE58OZ-IV2	VALFUN20-xxC9	ANEVAL20-89-xx	ORI81-xx	PARI81-12-I
SI 25	MEMSI25-xxOZ78V-V2ORGT	VALPRE58OZ-IV2	VALFUN20-xxC9	ANEVAL20-89-xx	ORI81-xx	PARI81-12-I
SI 35	MEMSI35-xxOZ78V-V2ORGT	VALPRE58OZ-IV2	VALFUN20-xxC9	ANEVAL20-89-xx	ORI81-xx	PARI81-12-I
SI42	MEMSI42-xxOZ78V-V2ORGT	VALPRE58OZ-IV2	VALFUN20-xxC9	ANEVAL20-89-xx	ORI81-xx	PARI81-12-I
SI 55	MEMSI55-xxOZ78V-V2ORGT	VALPRE58OZ-IV2	VALFUN20-xxC9	ANEVAL20-89-xx	ORI81-xx	PARI81-12-I

Replace xx with code of the rubber part as for table below

1	Nitrile (NBR)
1C	Low temp. nitrile (NBR -40°C)
1F	Nitrile for Hydrocarbons (NBR)
6	Hydrogenated Nitrile (H-NBR)
8	Epichlorohydrin (ECO)
2	Butyl
4	Ethylene/proylene (EPDM)
5	Chloroprene (Neoprene)
10	Fluororated rubber (FKM)

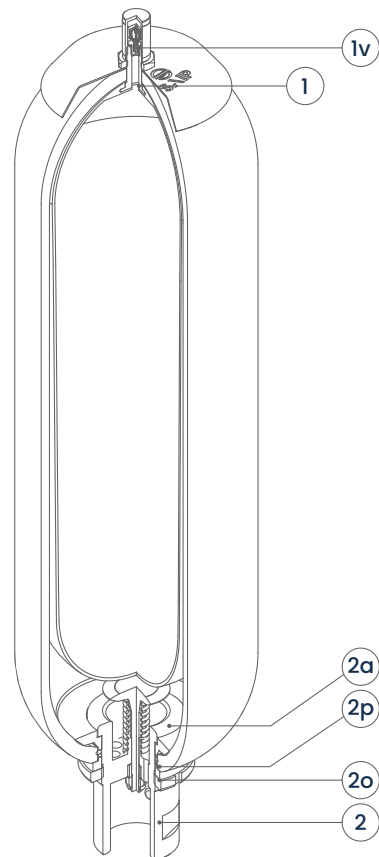

# Accessoires

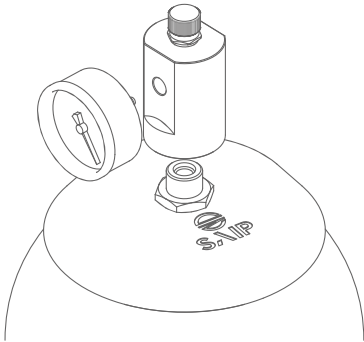

## Pressure monitoring gas side

Nozzle assembly with provision for mounting pressure gauge and/or fitting with rupture disk.

For codes or characteristics contact SAIP

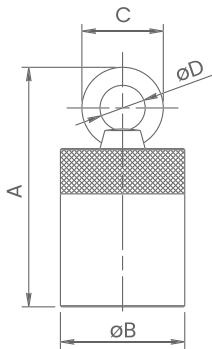

## Plug with lifting lug

Plug to be mounted on upper nitrogen-side valve 7/8" UNF. As a replacement for the standard cap.

For codes or characteristics contact SAIP

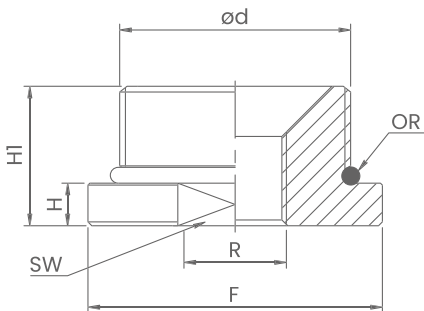

## Adapters and reductions for fluid connection

Adaptors and reductions for fluid connection: suppliable on request in different dimensions, materials etc.

For codes or characteristics please contact SAIP

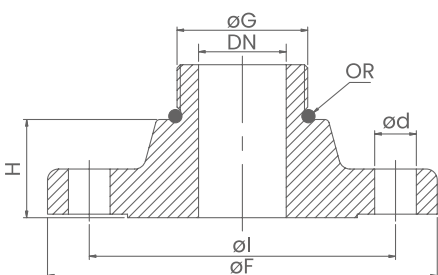

## Flange for fluid connection

Flange for fluid connection: suppliable on request for norm (i.e. ASME B16.5, EN1092-1) dimensions, different material, etc.

For codes or characteristics please contact SAIP

# Type SI bladder accumulators in carbon steel for pressures up to 360 bar



## Brackets and fixing collars

SAIP clamping brackets and collars can be used to securely fasten the various types of SI accumulators and ensure independent, non-rigid mounting on the installations. The rubber inserts serve to reduce vibration transmission, compensate for manufacturing tolerances and relieve the connection from external stress.

The brackets and collars are made of galvanised carbon steel; a stainless steel version can be supplied on request.

The support ring of the brackets and the band of the collars are made of black NBR nitrile rubber.

Brackets and collars can be easily bolted to the system or supports.

It is recommended to use only one collar when the length of the accumulator is less than twice the diameter.

It is recommended to use one bracket with support ring and one or two collars in other cases.

## Brackets with rubber ring support

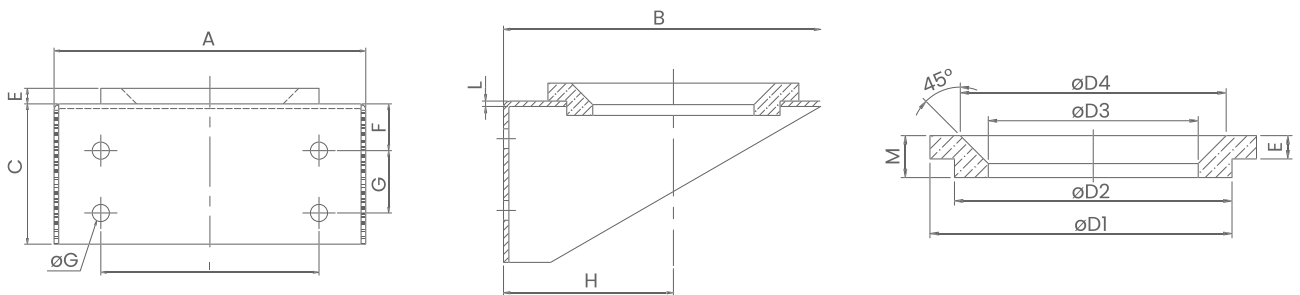

### Dimension

Part no. bracket	Part no. ring	A	B	C	D	D1	D2	D3	D4	E	F	G	H	I	L	M	Weight
mm																	
MOZ175-1	ANE175-1	200	177	90	10	140	120	91	114	10	30	40	95	140	3	18	1,6
MOZ260-1	ANE260-1	260	232	120	17	200	170	150	176	15	30	70	128	200	4	22	3,8

## Mounting clamps heavy series

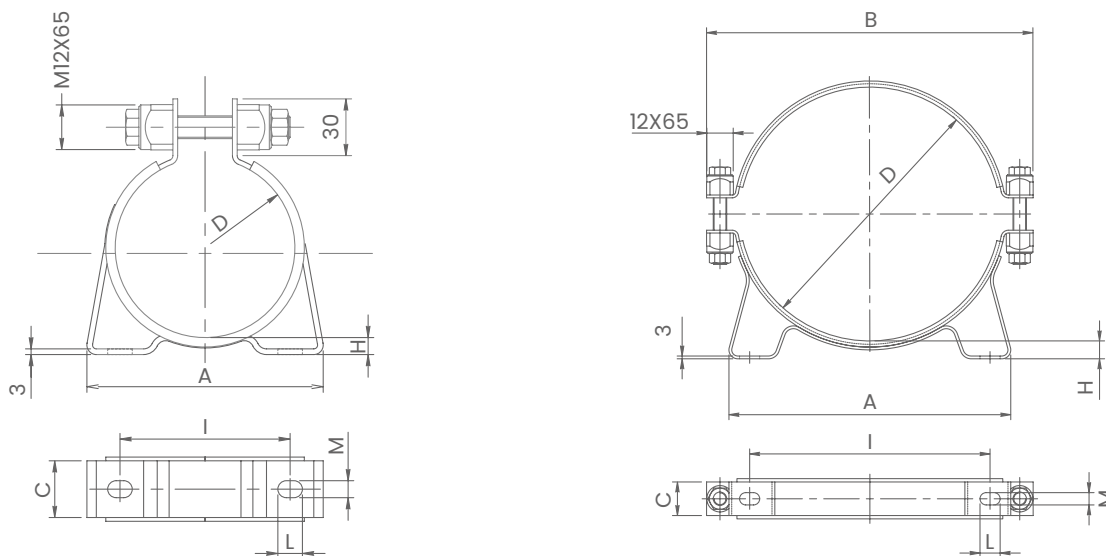

### Dimension

Part no.	A	B	C	D	H	I	L	M	Weight	Fig.	For accumulator Ø
	mm								Kg		
CFOZ95P	112		30	89÷95	9	90	13	9	0,65	I	90/94*
CFOZI20P	131	178	30	114÷122	11	100	13	9	0,85	II	114/120
CFOZI75P	182	237	30	168÷176	12	146	13	9	1,1	II	168/174
CFOZ220P	250	290	30	215÷227	16	215	18	11	1,35	II	220

## Mounting clamps light series

Type	Description						Weight
	Dmin	Dmax	A	B	C	E	
	[mm]	[mm]	[mm ±1]	[mm ±1]	[mm ±0,5]	[mm ±0,5]	
CFOZ72LF120	67	72	124	81	45	13	0,3
CFOZ96LF120			124	81	45	13	0,3
CFOZ96LF160	90	96	164	95	45	17	0,4
CFOZI11LF160	103	111	164	95	45	17	0,4
CFOZI20LF160	113	121	164	95	45	17	0,4
CFOZI37LF160	129	137	164	95	45	17	0,4
CFOZI46LF160			164	95	45	17	0,4
CFOZI46LF210	138	146	214	95	50	24	0,5
CFOZI59LF160			164	95	45	17	0,4
CFOZI59LF210	147	159	214	145	50	24	0,5
CFOZI72LF160			164	95	45	17	0,5
CFOZI72LF210	160	172	214	145	50	24	0,5

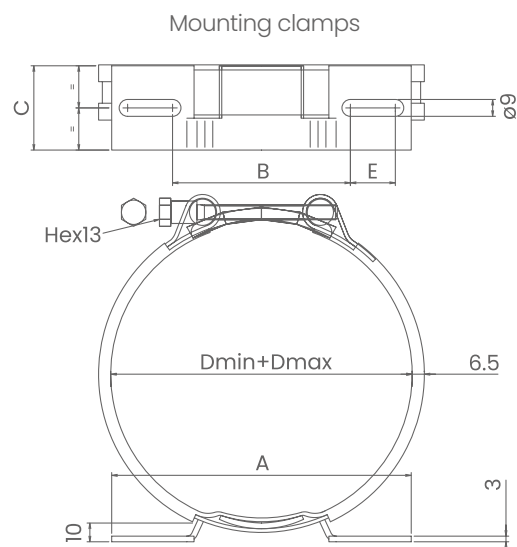



SI edition 2023 rev.0

[saip.it](https://www.saip.it)

**SAIP S.r.l.**  
Hydropneumatic  
Accumulator Company

Via Lambro 23/25/27  
20073 Opera (MI) Italy  
P.Iva 10218550159

[DOWNLOAD  
DATA SHEET](#)

