

saip.it



WAW Type

Welded
Diaphragm
Accumulators

Welded Diaphragm Accumulators WA Type



Principle Of Operation

One of the primary functions of hydraulic accumulators is to store a certain quantity of pressurized liquid from a hydraulic system and then release all or part of it back into the system when required. As pressurized vessels, they must be sized to withstand the maximum operational (over)pressure, while considering the acceptance standards applicable in the installation country. In the majority of hydraulic systems, accumulators with a separation element between the liquid side and the gas side are employed. Maintenance-free diaphragm accumulators, such as the WA type, consist of two high-strength steel caps that are electron-beam welded together. The U-shaped diaphragm separates the gas side from the liquid side. A dedicated bottom plate seals the opening on the liquid side when the accumulator is precharged to prevent diaphragm extrusion. The gas valve is available in the classic M28x1.5 version with a locking hexagon socket screw and a metal-rubber sealing washer (for precharging, the DPI00 precharging and control equipment must be used). The liquid connection is available in standard threaded connections as specified in the table, in both female and double-threaded versions for quick, secure, and cost-effective anchoring through the external threading and locking nut (optional, see Accessories section), as well as an appropriate female connection. Compared to other types of accumulators, these diaphragm accumulators offer high energy efficiency due to their higher energy density (energy content per unit mass). This characteristic is attributed to the nearly spherical shape of the accumulator body. WA Type Diaphragm Accumulators can be installed in any position. Maintenance-free WA type diaphragm accumulators cannot be repaired.

Product Description

Non-repairable diaphragm accumulator with carbon steel caps, electron-beam welded, and painted, designed for use in mobile machinery and stationary systems.

Applications

- Energy storage in intermittent operation systems for pump power reduction.
- Energy reserve for emergency situations, such as pump unit failure or power outage.
- Compensation for losses due to leakage.
- Pressure compensation (balancing).
- Vibration damping in cases of periodic oscillations.
- Volume compensation in the presence of pressure and temperature variations.
- Hydraulic suspension spring for vehicles.
- Shock absorption in the event of mechanical impact.

Features

- A** Upper Cap
- B** Ring
- C** Diaphragm
- D** Bottom Plate
- E** MAG Welding
- F** Liquid Connection
- G** Lower Cap
- H** Electron Beam Welding

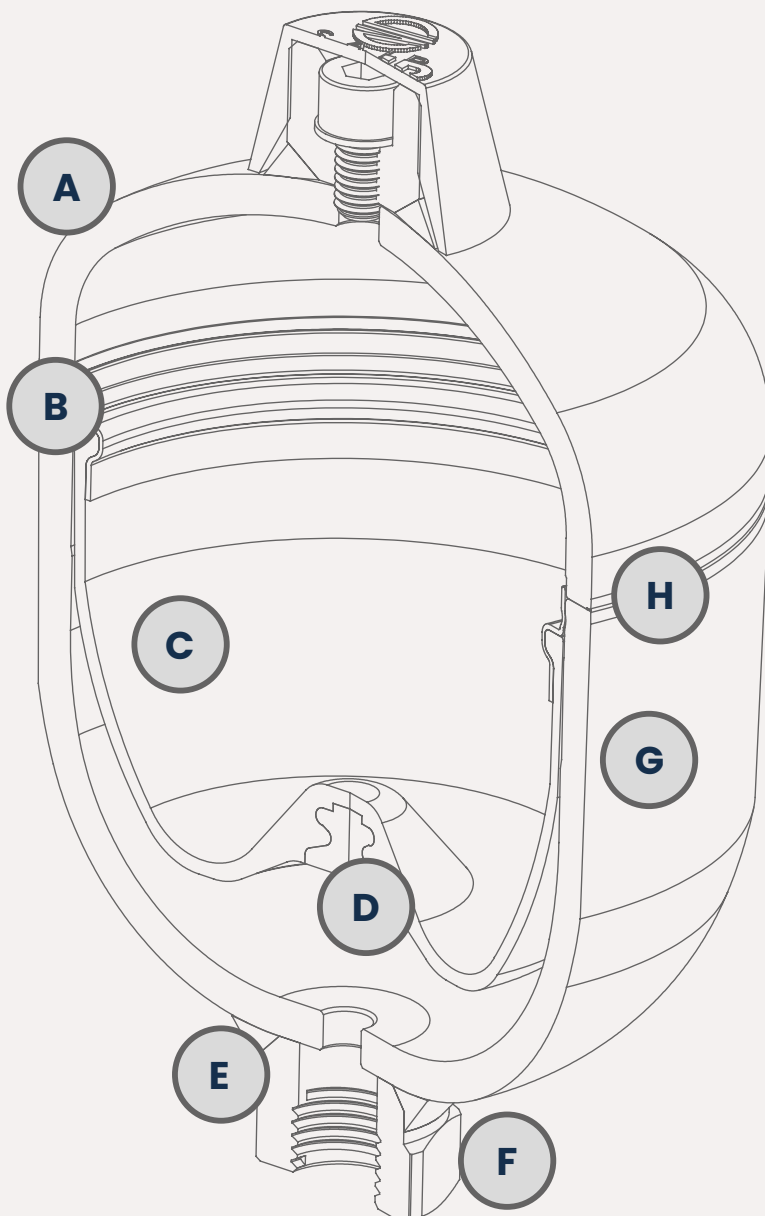

General Features

Nominal Volume
from 0.05 to 3 liters

Maximum pressure
Up to 80 barg

Compliant with
PED 2014/68/EU EN
14359:2017
EN13445-3:2021
standards

Technical specifications

Non-repairable
electron beam welded
construction

High-strength alloy
steel body

Standard painting

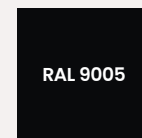

Two-component
anti-corrosion primer with
water-based epoxy resins

Gas side connection: M28x1.5

Fluid side connection
(see table)

Separator element
material (see table)

Description

Electron Beam Welded Diaphragm Accumulator WA Type - M28x1,5 - Vol. 0.75 L - NBR - Carb. Acc. - Fem. 1/2" GAS - Mod. 210 bar

EXAMPLE CODE*															
WA	.	2	.	0,75	.	1	.	O	.	G4	.	A	.	210	
1		2		3		4		5		6		7		8	
1. ACCUMULATOR TYPE		2. GAS CONNECT (NITROGEN)		3. NOMINAL VOLUME		4. SEPARATOR ELEMENT MATERIAL		5. BODY MATERIAL		6. LIQUID CONNECTION		7. CERTIFICATION		8. DESIGN PRESSURE	
WA		2 CONNECTION M28X1,5		0,05 L		1 NITRILE (NBR)		O CARBON STEEL		G4 F. 1/2" BSP-P		A PED 2014/68/EU EN 14359:2017 EN13445-3:2021		210	
				0,16 L		8 EPICLORIDRINA (ECO)				E1 M. M33X1,5 + F. 1/2" BSP-P				250 250 BARG	
				0,35 L						M8 F. M18X1,5				100 100 BARG	
				0,5 L						G4 F. 1/2" BSP-P				250 250 BARG	
				0,75 L						E1 M. M33X1,5 + F. 1/2" BSP-P				100 100 BARG	
				1 L						M8 F. M18X1,5				250 250 BARG	
				1,4 L						G4 F. 1/2" BSP-P				210 210 BARG	
				2 L						E1 M. M33X1,5 + F. 1/2" BSP-P				280 280 BARG	
				3 L						M8 F. M18X1,5				210 210 BARG	
										G4 F. 1/2" BSP-P				140 140 BARG	
										E1 M. M33X1,5 + F. 1/2" BSP-P				250 250 BARG	
										Y9 F. 3/4" BSP-P				140 140 BARG	
										E7 M. M45X1,5 + F. 3/4" BSP-P				250 250 BARG	
										Y9 F. 3/4" BSP-P				250 250 BARG	
										E7 M. M45X1,5 + F. 3/4" BSP-P				250 250 BARG	

* For different codes or specifications, please contact SAIP.

Membrane Compatibility / Temperature / Fluido *

1	Nitrile Butadiene Rubber (NBR)	-15 / +80°C	<p>Suitable for: Mineral greases and oils.</p> <p>Aliphatic hydrocarbons (propane, butane, gasoline, mineral oils, diesel fuel, heating oil, kerosene).</p> <p>HFA - HFB - HFC fluids.</p> <p>Many diluted acids.</p> <p>Saline solutions.</p> <p>Water.</p> <p>Water-glycol solutions.</p>
8	Epichlorohydrin Rubber (ECO)	-30 / +120°C	<p>Low gas permeability, good resistance to ozone, aging, and atmospheric agents. Suitable for:</p> <p>Mineral greases and oils.</p> <p>Aliphatic hydrocarbons (propane, butane, gasoline).</p> <p>Silicone oils and greases.</p> <p>Water at room temperature.</p>

* For use with other fluids and/or temperatures, please contact SAIP.

Liquid Connection

G4	F. 1/2" BSP-P (without grooving)
M8	F. M18x1,5 (without grooving)
Y9	F. 3/4" BSP-P (with grooving ø34)
E1	M. M33x1,5 + F. 1/2" BSP-P (without grooving)
E7	M. M45x1,5 + F. 3/4" BSP-P (without grooving)

Technical Drawing / FORM G - M - Y

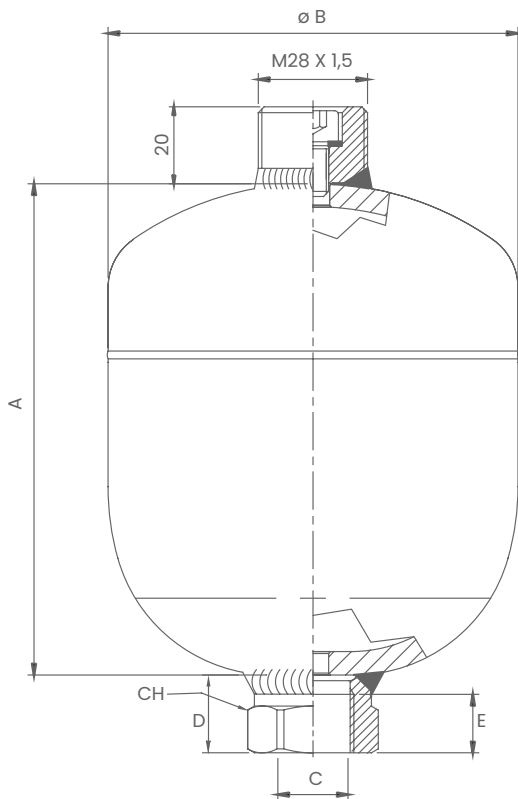

Technical Drawing / FORM E

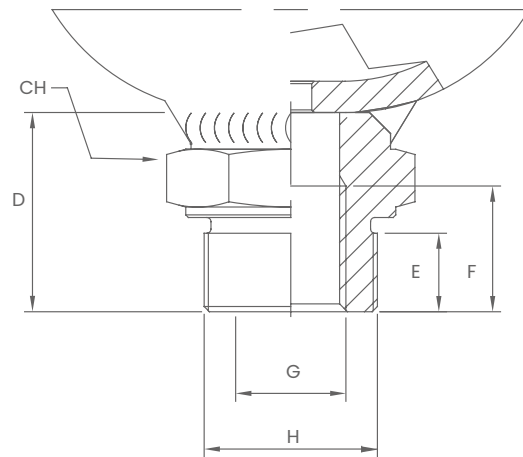

Technical Data

Type	Nominal volume	Actual volume	Design pressure *	MAX ΔP ** dynamic $P_2 - P_1$	MAX Compression ratio $P_0 : P_2$	MAX *** Flow rate	MAX **** Precharge	PED Category for liquids Group 2	Weight
	[L]	[L]	[barg]	[barg]		[L/min]	[barg]		[kg]
WA 0,05	0,05	0,07	250	120	8:1	10	130	Art.4 Par.3	0,5
WA 0,16	0,16	0,17	250	120	8:1	10	130	Art.4 Par.3	0,9
WA 0,35	0,35	0,36	100	100	8:1	40	70	Art.4 Par.3	1,0
		0,40	250	140	8:1	40	130	Art.4 Par.3	1,7
WA 0,5	0,5	0,59	210	140	8:1	40	130	Art.4 Par.3	2,2
WA 0,75	0,75	0,77	100	150	6:1	40	70	Art.4 Par.3	2,0
		0,72	210	120	4:1	40	130	Art.4 Par.3	2,8
		0,81	280	150	4:1	40	130	Art.4 Par.3	3,1
WA 1	1	1,00	210	140	4:1	40	130	Art.4 Par.3	3,5
		1,00	280	140	4:1	40	130	Art.4 Par.3	3,7
WA 1,4	1,4	1,42	140	80	6:1	40	100	Cat: I	4,0
		1,49	250	140	6:1	40	130	Cat: II	5,5
WA 2	2	2,00	140	60	4:1	130	100	Cat: II	4,8
		2,05	250	140	4:1	130	130	Cat: II	6,5
WA 3	3	3,00	250	140	4:1	130	130	Cat: II	10,0

* Design Pressure calculated in accordance with EN14359:2017 (for pressure values in accordance with other standards, please contact SAIP).

** Maximum Allowable Differential Pressure (difference between maximum operating pressure P_2 and minimum operating pressure P_1) for an infinite cycle life (greater than 2,000,000 cycles).

*** Flow rate measured using mineral oil with a viscosity of 36 cst at 50°C and $\Delta P = 5$ bar.

**** For values higher than this, please contact SAIP.

Dimensions

Type	Design pressure [barg]	Gas connection (Nitrogen)	A [mm]	B [mm]	Form G/M/Y				Form E					
					C	E [mm]	D [mm]	CH [mm]	G	H	E [mm]	F [mm]	D [mm]	CH [mm]
WA 0,05	250	M28x1,5	65	55	F. 1/2" BSP-P	15	20	30	-	-	-	-	-	-
WA 0,16	250	M28x1,5	81,7	69	F. 1/2" BSP-P	15	20	30	F. 1/2" BSP-P	M. M33x1,5	15	24	38	41
					F. M18x1,5	15	20	30						
WA 0,35	100	M28x1,5	99	91,5	F. 1/2" BSP-P	15	20	30	F. 1/2" BSP-P	M. M33x1,5	15	24	38	41
	250	M28x1,5	112	97	F. 1/2" BSP-P	15	20	30	F. 1/2" BSP-P	M. M33x1,5	15	24	38	41
WA 0,5	210	M28x1,5	126	105	F. 1/2" BSP-P	15	20	30	F. 1/2" BSP-P	M. M33x1,5	15	24	38	41
					F. M18x1,5	15	20	30						
WA 0,75	100	M28x1,5	134	109	F. 1/2" BSP-P	15	20	30	F. 1/2" BSP-P	M. M33x1,5	15	24	38	41
	210	M28x1,5	132	117	F. 1/2" BSP-P	15	20	30	F. 1/2" BSP-P	M. M33x1,5	15	24	38	41
					F. M18x1,5	15	20	30						
280	M28x1,5	132	117	F. 1/2" BSP-P	15	20	30	F. 1/2" BSP-P	M. M33x1,5	15	24	38	41	
WA 1	210	M28x1,5	168	117	F. 1/2" BSP-P	15	20	30	F. 1/2" BSP-P	M. M33x1,5	15	24	38	41
	280	M28x1,5	168	117	F. 1/2" BSP-P	15	20	30	F. 1/2" BSP-P	M. M33x1,5	15	24	38	41
WA 1,4	140	M28x1,5	153,2	143	F. 1/2" BSP-P	15	20	30	F. 1/2" BSP-P	M. M33x1,5	15	24	38	41
	250	M28x1,5	154	153	F. 1/2" BSP-P	15	20	30	F. 1/2" BSP-P	M. M33x1,5	15	24	38	41
WA 2	140	M28x1,5	196	143	F. 3/4" BSP-P	18	22	40	F. 3/4" BSP-P	M. M45x1,5	19	18	42	46
	250	M28x1,5	193	153	F. 3/4" BSP-P	18	22	40	F. 3/4" BSP-P	M. M45x1,5	19	18	42	46
WA 3	250	M28x1,5	242	174	F. 3/4" BSP-P	18	22	40	F. 3/4" BSP-P	M. M45x1,5	19	18	42	46

Liquid connection

G4 F. 1/2" BSP-P (without grooving)

M8 F. M18x1,5 (without grooving)

Y9 F. 3/4" BSP-P (with grooving ø34)

E1 M. M33x1,5 + F. 1/2" BSP-P (without grooving)

E7 M. M45x1,5 + F. 3/4" BSP-P (without grooving)

Sizing

The sizing of an accumulator requires the consideration of various factors:

- Minimum (P_1) and maximum (P_2) working pressures.
- Minimum (T_1) and maximum (T_2) working temperatures.
- Precharge pressure (P_0).
- Required volumes.

For the correct sizing, you can find the formulas in the document under the section

GENERAL INFORMATION -> SIZING

Status conditions

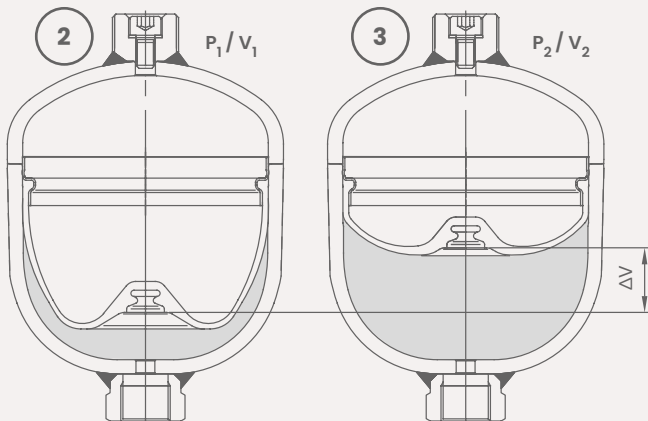
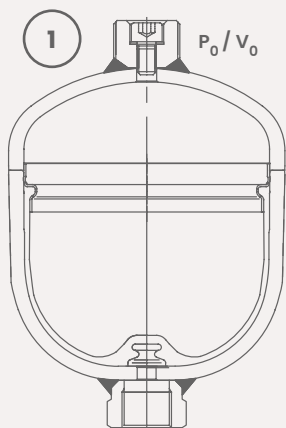

Certifications

All hydraulic accumulators are pressure vessels and are subject to national regulations and the directives applicable in the country of installation. WA type accumulators are constructed in accordance with the European Directive PED 2014/68/EU. In the Technical Data table, the category of use is specified for non-hazardous fluids (Group 2). For use with hazardous fluids (Group 1), please contact SAIP. For other countries, applications, or regulations, please get in touch with SAIP for further information and guidance.

Usage informat

Please refer to the following SAIP documents:

- WA USER AND MAINTENANCE MANUAL

- USER MANUAL FOR THE STORAGE AND PRESERVATION OF HYDRAULIC ACCUMULATORS/PULSATION DAMPENERS

Safety Equipment

Warning:

Hydropneumatic accumulators must be protected against operation beyond permissible limits in accordance with Directive 2014/68/EU on pressure equipment.

To avoid exceeding the maximum operating pressure, SAIP recommends the use of a safety block.

CAUTION!

HIGH PRESSURE ACCUMULATOR. NEVER USE OXYGEN OR SHOP AIR.

1. Do not operate without sufficient dry nitrogen gas precharge.
2. Release all pressure prior to servicing or disassembly.
3. Consult the instruction manual before use.
4. Do not operate beyond stamped maximum working pressure.
5. Do not weld or modify this unit in any way.

Spare parts

VITCM814TF-O12-B

Closure Screw

GUAUSITM8-1

Usit-Ring Washer

TPPERM2V

Upper Protective Cap

Accessories

Fastening Nut

Used for securely and easily fastening accumulators through the external threading on the fluid side fitting M33x1.5 or M45x1.5 and/or through the gas side connection M28x1.5 threading.

The nuts are made of carbon steel with a white zinc plating treatment, providing excellent corrosion resistance.

Fastening Collars

The SAIP fastening collars, CFOZ_LF_ type, can be used to securely fasten various types of WA accumulators and ensure independent and non-rigid mounting on systems. The rubber insert serves to reduce vibration transmission, compensate for manufacturing tolerances, and relieve the connection from external stresses. This type of collar has a two-piece structure for easier installation, greater modularity, and stability according to requirements and available space. The base plate is made of white zinc-plated carbon steel with excellent corrosion resistance. The band that secures the accumulator to the base is constructed from carbon steel with the same characteristics as the base and is isolated from the accumulator body by a Nitrile Butadiene Rubber (NBR) strip.

TECHNICAL DRAWING / COLLAR

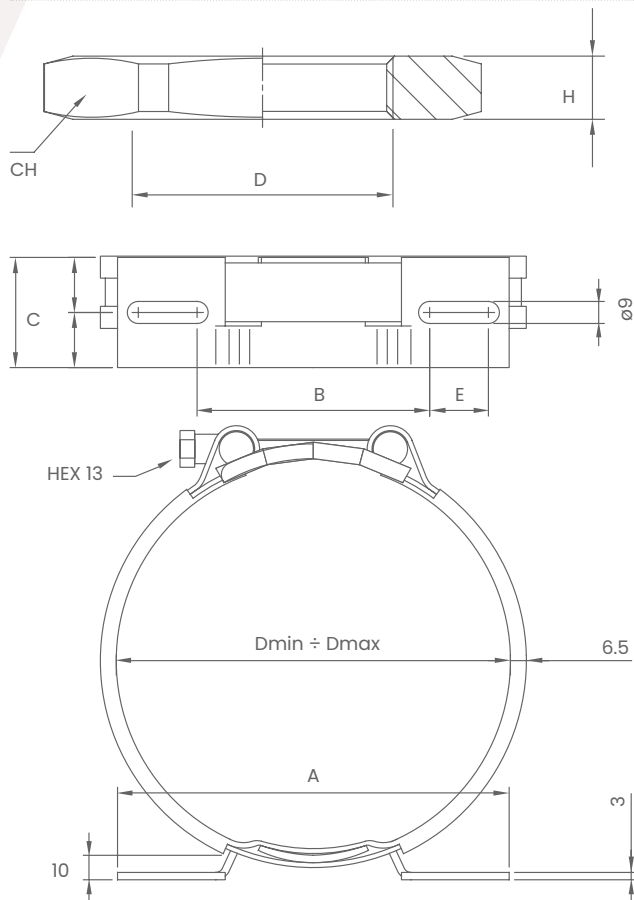

Type	Description						Weight	WA usage
	Dmin	Dmax	A	B	C	E		
	[mm]	[mm]	[mm ±1]	[mm ±1]	[mm ±0,5]	[mm ±0,5]		
CFOZ72LF120	67	72	124	81	45	13	0,3	WA 0,16
CFOZ96LF120	90	96	124	81	45	13	0,3	WA 0,35
CFOZ96LF160			164	95	45	17	0,4	
CFOZ111LF160	103	111	164	95	45	17	0,4	WA 0,5 [210/300]
								WA 0,75 [100]
CFOZ120LF160	113	121	164	95	45	17	0,4	WA 0,75 [210/280]
								WA 1 [210/280]
CFOZ137LF160	129	137	164	95	45	17	0,4	WA 1 [250]
CFOZ146LF160								138
CFOZ146LF210			214	95	50	24	0,5	
CFOZ159LF160	147	159	164	95	45	17	0,4	WA 1,4 [250]
CFOZ159LF210			214	145	50	24	0,5	WA 2 [250]
CFOZ172LF160	160	172	164	95	45	17	0,5	WA 3 [250]
CFOZ172LF210			214	145	50	24	0,5	



WA edition 2023 rev.0

saip.it

SAIP S.r.l.
Hydropneumatic
Accumulator Company

Via Lambro 23/25/27
20073 Opera (Mi) Italy
P.Iva 10218550159

[DOWNLOAD
DATA SHEET](#)

