



Use, maintenance, storage
and preservation
manual for hydropneumatic
accumulators/pulsation
dampeners



Use, maintenance, storage and preservation manual for hydropneumatic accumulators and pulsation dampeners

1. INTRODUCTION

This product can only be used (transport, storage, installation, commissioning, operation, repair or otherwise) after reading and carefully understanding these instructions and the manual providing information on safety. If you cannot understand the languages of this manual, contact Saip to obtain a translation.



CAUTION

The sections of the text marked with this pictogram contain safety instructions. Non-compliance with these instructions can cause accidents, damage to materials and/or personal injuries and invalidates our liability and warranty.

Read these instructions fully and carefully before any use. Use is limited to professional users who are qualified and experienced. If in doubt or if you have questions, contact the authorised dealer or SAIP directly:

SAIP S.r.l. Via Lambro, 23/25/27 20073 Opera (MI) Italia
 Tel: 02 57 60 39 13 Email: saip@saip.it
 Sito web: www.saip.it

2. INTRODUCTION OF THE PRODUCT, INTENDED USE, SUPPLY

Hydropneumatic accumulators consist of a fixed external body, static seals, any internal moving parts (diaphragm, bag, piston, bellows, fluid-side foot valve) and a gas valve to introduce nitrogen precharge. Hydropneumatic accumulators are pressure vessels charged with nitrogen, for use in hydraulic/fluid systems as energy reserves, pressure and/or volume compensators, pulsation dampers or water hammer absorbers.



CAUTION

Other uses should be considered misuse if not properly evaluated; you can contact SAIP for any requirements.

Only professional and qualified users can carry out installation and maintenance. Also always consult the manufacturer's manual of the hydraulic system. According to the type, the accumulators/dampeners can have 3 types of gas closure devices:



M28x1.5



5/8" UNF



1/4" BSP

3. GENERAL SAFETY INSTRUCTIONS

Pay attention to the symbols in this document and, if necessary, on the product. They indicate danger.

	CAUTION Pressurised nitrogen and pressurised hydraulic fluid. Always consult the manual of the hydraulic system.	
	Danger of high temperatures. The Hydropneumatic Accumulators/Pulsation Dampeners can overheat during operation; after depressurising the system, leave to cool	
	On each use, think about your safety. Wear adequate protection such as clothing, goggles, shoes and gloves.	
	Use COMPRESSED NITROGEN ONLY (99.99% recommended), never use other types of gas: DANGER OF EXPLOSION.	
	To avoid choking, storage and maintenance are only permitted in adequately ventilated premises.	
	The fluids released at high pressure can pierce the skin and cause serious injuries and risk of infection. If injured, immediately consult a doctor!	
	To avoid risks of explosion or fire, do not expose the unit to sources or direct or indirect heat.	
	Never exceed the maximum working pressure printed on the unit. Install a safety system that protects the accumulator/dampener from unwanted excess pressure.	
	CAUTION Movement of the accumulator/pulsation dampener must be carried out with suitable lifting devices.	

4. SAFETY MANAGEMENT INSTRUCTIONS

Internal transport, movement and storage

Handle with care. Use adequate lifting equipment when necessary.

	Pay attention to the gas valve. NEVER use it to lift the accumulator/dampener.
---	---

Unpacking

Handle it with care. Always check for components damaged before use.

	Do NOT install or use damaged parts.
---	---

Labelling and markings

Check labelling and marking of the accumulator/dampener. Leave the labels and the marking visible when assembling the accumulator/dampener. The marking indicates the maximum permitted use limits. An example of marking follows.

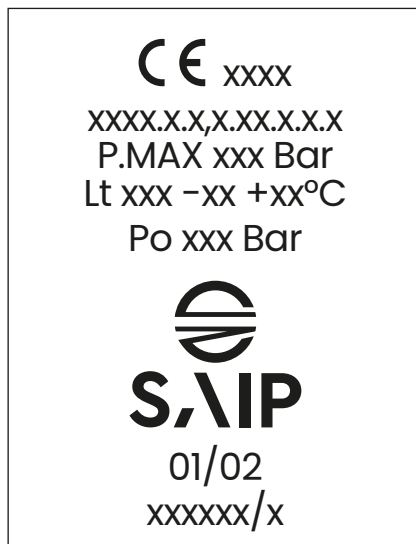

Reference

CE XXXX	Regulations applicable to the country of destination
xxxx.x.x,x.xx.x.x.x	Type of assembly
P.MAX	Maximum pressure
Lt	Assembly capacity
-xx +xx°C	Working temperature delta
P0	Pre-charge pressure
	SAIP Brand
01	Month of manufacture
02	Year of manufacture
xxxxxx/x	Serial number



DO NOT install or use the accumulator/dampener outside the maximum limits indicated on the accumulator itself.

Installation

The position of the accumulator should preferably be vertical (with high gas valve) as horizontal installation can reduce the life of the accumulators.

If installed in a seismic area, check that the accumulator has been properly secured and stabilised.

Also check that:

- the plate has clearly displayed the pre-charge value.
- leave at least 25 cm to use the pre-charge device.
- where necessary, the SAIP collars and shelves are always used for correct and safe fastening.



It is strictly forbidden to make structural changes such as welding, turning or otherwise for installation. Risk of **EXPLOSION**.



NEVER install the unit in the vertical position with the gas valve turned downwards (except for Diaphragm and Piston versions).

Example of hydraulic outline

1. Accumulator.
2. Check valve.
3. Pump.
4. Gauge.
5. Ensure a pressure relief valve is installed with direct connection with the accumulator/dampener.
6. Opening to limit the flow during the discharge of the accumulator/dampener.
7. Shut-off valve for system de-pressurisation.

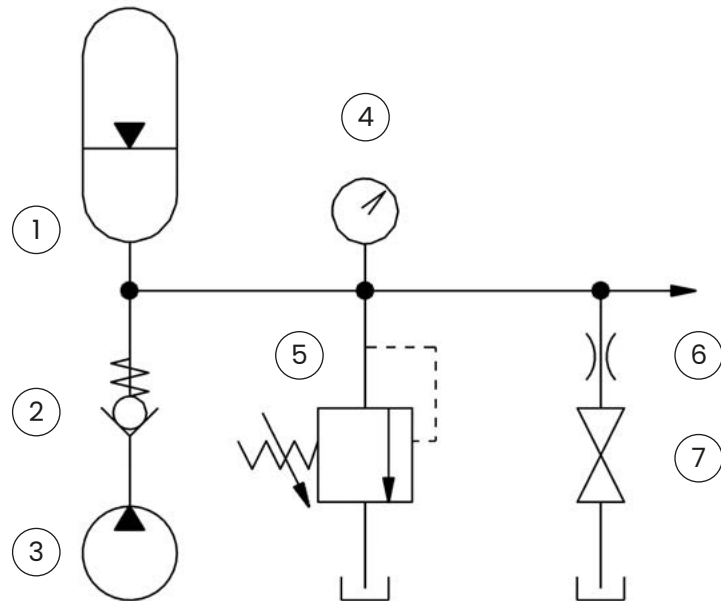

NEVER install the accumulator/dampener without having the possibility of controlling the nitrogen charge pressure.
NEVER install the accumulator/dampener without the possibility of discharging the hydraulic pressure.



NEVER exceed the maximum working pressure printed on the accumulator/dampener.
 The safety valve must be calibrated and operate at a pressure lower than the accumulator nameplate rating.



Start the system, instructions for use and maintenance

Carefully inspect the system.

Ensure that the battery model is suitable for the area where it will be installed (e.g. explosion-hazardous areas) Ensure the accumulator/dampener is pre-charged.













Proceed to start the system.

Ensure that the process fluid is suitable for the materials of construction of the accumulator.

Then, pressurise the system, slowly increasing the hydraulic pressure, checking there are no leaks. If necessary, purge the air.

Slowly bring the system to the desired pressure.

Check the pre-charge pressure of the gas one month after and then periodically every six months.

	Danger of high temperatures. The hydropneumatic accumulators can overheat during operation. If the temperature exceeds 20°C, take into account the temperature range during the pre-charging phase.	
	NEVER exceed the maximum pressure and temperature values printed on the accumulator/dampener. The safety valve must be calibrated under the maximum pressure indicated.	
	Use COMPRESSED NITROGEN ONLY (99.99% recommended), never use other types of gas: DANGER OF EXPLOSION .	
	The fluids released at high pressure can pierce the skin and cause serious injuries and risk of infection. If injured, immediately consult a doctor!	
	The pre-charge pressure must be a maximum of 9/10 of the minimum working pressure and, at least 1/4 of the maximum working pressure.	
	Protect the equipment against exposure to fire from external sources by using extinguishing systems and protection against exceeding the maximum pressure limit.	





Decommissioning

Always consult the user manual of the entire hydraulic system before disconnecting any part.

Completely depressurise the hydraulic system.

Completely discharge the nitrogen using the precharge device.

Carefully unscrew the accumulator/dampener from the system.

	Make sure the hydraulic system is completely depressurised before proceeding with the removal of the accumulator/pulsation dampener.	
	The Hydropneumatic Accumulator/Pulsation Dampener may overheat during use. Leave to cool before dismantling it from the system.	

Repair

For detailed instructions on repair, contact your dealer or the SAIP technical service by e-mail saip@saip.it

Disposal instructions

Please refer to the disposal of the components and fluids used in strict compliance with local regulations.

Main materials of the components for disposal:

- Accumulator body: carbon steel / stainless steel / duplex / super duplex / super alloys / PVC / polypropylene
- Diaphragm / Bag: rubber / plastic
- Other components: consult the drawing or technical data sheet of the product where the materials of the individual components and accessories are indicated

5. DECLARATION OF CONFORMITY

This product complies with the essential requirements and other provisions of Directive 2014/68/EU (Pressure equipment directive) or the specific directives of the country of destination.



Save a copy of this manual and the Declaration of Conformity of the accumulator/dampener. It must be available for consultation for 10 years after delivery.

6. UNPACKING AND STORAGE

Under the activities of preservation of our products:

- Lift the accumulator carefully and use suitable and certified lifting devices, ensuring that the accumulator is balanced before lifting.
- Accumulators, once removed from the packaging, must be mounted directly on the system or placed in an indoor warehouse.
- During warehouse storage, the bag's preload and lubrication should be checked every six months to ensure proper product preservation.



CAUTION

Movement of the accumulator/pulsation dampener must be carried out with suitable lifting devices.



7. ANNEXES

Annex I

Instructions to pre-charge and check the Hydropneumatic Accumulators/ Pulsation Dampeners:

- with device type DP 100 (for gas valve M28 x 1.5 up to 350 bar);
- with device type DP 200 (for gas valve 5/8" UNF up to 350 bar)
- with device type DP 300 (for gas valve 1/4" BSP up to 690 bar)



Annex I.pdf





Use, maintenance, storage and preservation manual for
hydropneumatic accumulators/pulsation dampeners
rev.3 April 2026

saip.it

SAIP S.r.l.
Hydropneumatic
Accumulator Company

Via Lambro 23/25/27
20073 Opera (MI) Italia
P.Iva 10218550159